

Quick Change Frames



The contents and designs contained within this manual are copyrighted, patent pending, trademarked or patented 2023

*2 New Banner Stretching
Frames Inside, plus a new
narrower profile LED frame*

A quick guide and outline of our frame products.
We provide the best quality available at low cost.

Displaying Graphics Beautifully!

Contact:

Table of Contents

Frame Basics	3
Cloudlight LED frames any size	4
Fabric Frames	5-6
Frame 1 FF-ST Flip-Up™ 1.25" wide profile	7-8
Frame 1 FF-ST Flip-Up™ 2.50" wide profile	9
Frame 2 FF-RP Security Flip-Up™ 1.25" wide profile	10
Frame 2 FF-RP Security Flip-Up™ 1.75" wide profile	11
Frame 3 SL-ST edge load Slide-In™ 1.0" wide profile	12
Frame 4 Round Mini Flip-Up™ .60" "skinny" profile	13
Frame 4 Square Mini Flip-Up™ .60 "skinny" profile	14
Frame 5 RCOR1.0™ Flip-Up™ Round Corner 1.0" wide profile	15
Frame 6 RCOR1.25™ Flip-Up™ Round Corner 1.25" wide profile	16
Frame 7 Armored Steel Sign Holder	17
Unique Angled Frames and custom imprinted frames	18
Banner Grip™ 4.0" wide banner stretching frame	19-23
Banner Grip™ Flip Model stretching frame	24
Banner Jr Model Stretching Frame	25
2 New Banner Stretching Frames Profile Dimensions and Photos	26-27
Stands, A-Frames and uprights any size	28
Security /Anti-tamper Options for frames	29
Overlay lenses, frame backers and other options	30
Acrylic Standoff Frames	31
Bollard Mount, Single and Dual Frame System	32
Cubicle Sneeze Dividers	33
Customer-supplied pictures	34-36

Frame Basics

All frames can be used for both interior and exterior use. They are made for mounting on flat surfaces for easy installation of your signs, graphics and banners. No removal of frames required for fast and easy graphic changes. We have no minimums, you can order just 1 frame -any size, for any thickness graphic. Large frames are sent un-assembled for low cost and no transit damage, and super large frames join seamlessly with our exclusive “joiner strap” to connect longer pieces.

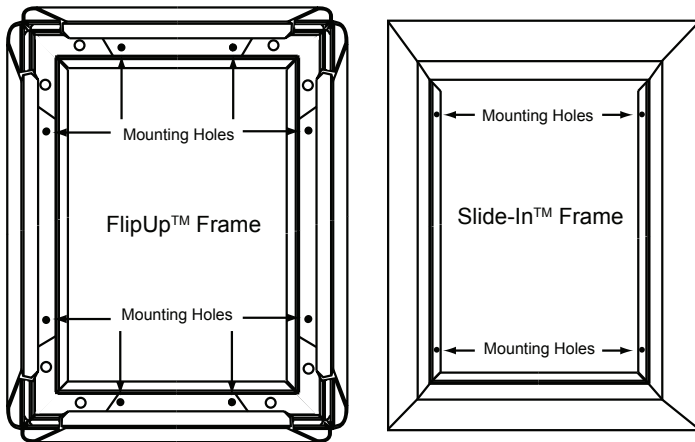

Easy, fast assembly on site.

The frames are cut to order to meet your exact specifications.

All frames have predrilled holes about 2” from corners for easy wall mounting. Mounting hardware included and other mounting options are available upon request such as slatwall, D ring ceiling hanging, etc.

Our frames look like permanent mitered frames, with their opening/loading features concealed. Nonetheless, we do offer security options for most all our frames to protect from the graphic being removed or stolen. See page 17 for Security Options.

The frames can be made to hold various insert thicknesses -“IT”. Knowing the approximate thickness of graphic material going into the frame tells us what bottom pieces to use and how to cut the frames to avoid any gaps at the mitered edges. Graphic Thickness selections: (total thickness of everything going into the frame): thin graphics, (under .100”), .100” - .125” thickness, .126” - .250” thickness, and .251” - .500” thickness.

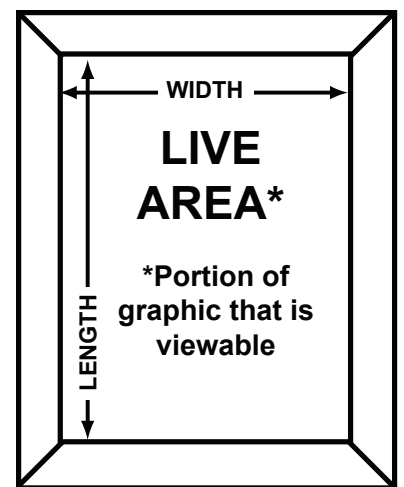
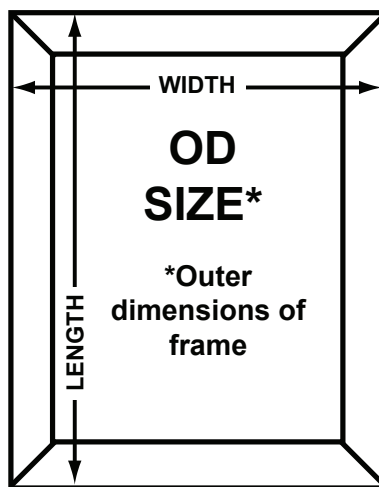
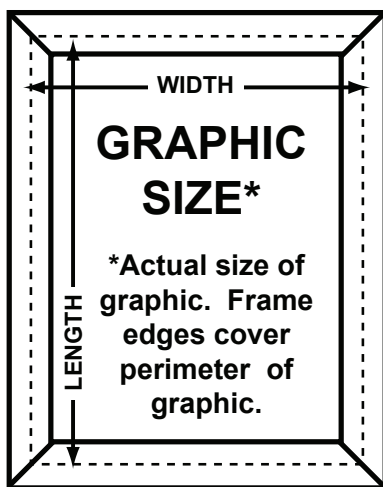

There are three measuring methods Graphic Size, Outside Dimensions (OD Size), or Live Area. When ordering, tell us the size and measuring style. The most popular method is Graphic Size – the actual cut sheet size of the poster. OD Size is the overall size or outer-most length x width of the frame. Live Area is the viewable area of the graphic once the frame edges are closed. When ordering by OD size or Live area, we will provide the corresponding size your graphic needs to be. The online system will automatically show ALL 3 measurements for your convenience.

For indoor and outdoor use

CLOUDLIGHT™ LED FRAMES

For indoor and outdoor use

Bring your message to life with our new Cloudlight LED Frames. Our stylish and convenient front-loading Flip-Up frames are now available as LED edge lit frames. Utilizing super bright LEDs that illuminate the entire surface of the acrylic, ***our edge-lit frames deliver a brilliant graphics display, uniform light distribution, and energy savings, and long life.***

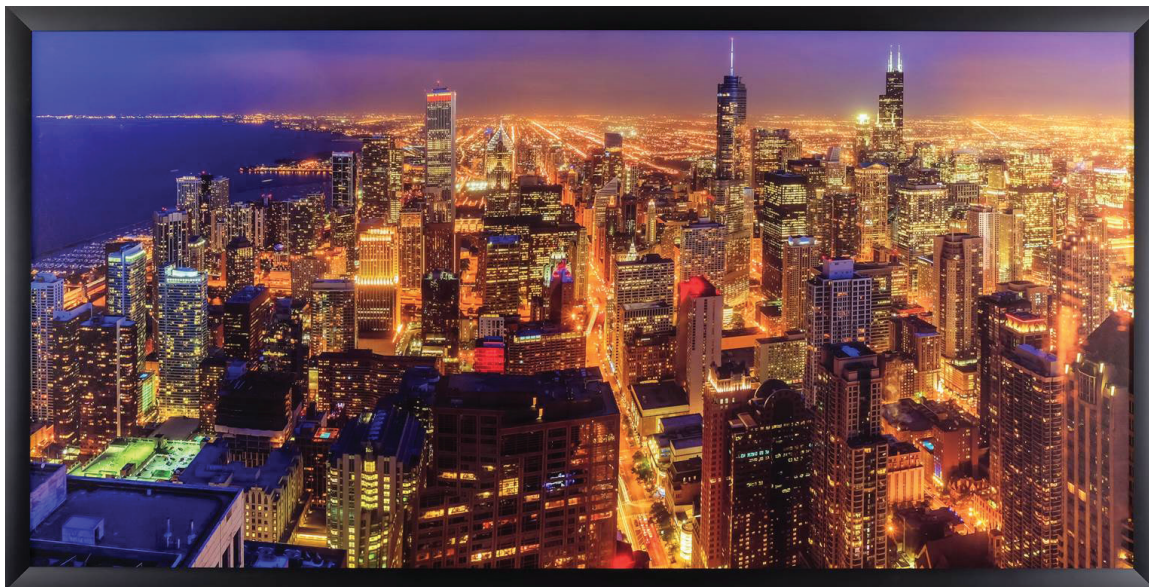

Beautiful Chicago skyline at night. Size: 54" x 109" less than 1" thick.
Any size, any color, 1 minimum. Low Cost. Best Quality. Made in Chicago

- **Bright, Warm White Light at 6,000K**
- **Dimmer/flashing switch included** to set the exact brightness level you want or fade in/fade out options
- **Thin Frame Profile** - only .96" thick
- **Mounts flush to wall** -you tell us if where you want cord to exit, out the back of frame or edge of frame
- **Long Life and Low Maintenance and Energy usage** – 50,000 hours and 2 year limited warranty
- **Fast Signage Changes** - flip open sides, insert graphic
- **15 Frame Color Choices, Faux Woods, 4 profile choices**
- **Easy Installation** – just mount to wall with included fasteners and plug into the outlet or hard wire
- **Made to order** any size, minimum 1
- **Security and Anti-Tampering** options available
- **Made in most any size for indoor and wet outdoor use.**
For outdoor use let us know as it is constructed differently.
- **High Quality Anodized Aluminum** - 30% recycled material
- **Free Ground Shipping** on orders over \$75 to continental US for sizes 24" x 36" and smaller
- **Made in Chicago, IL USA** for **FAST** Delivery nationwide

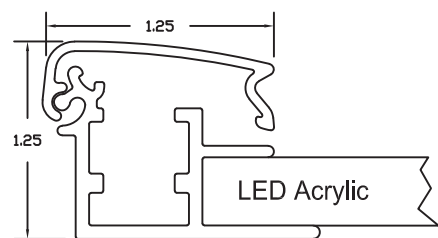

Standard 1.25 inch wide top LED frame

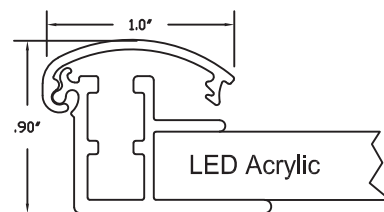

Smaller 1 inch wide LED frame

American Owned



American Made

Fast Change Fabric Frame

Introducing Fabric Frames custom made to any size, 1 minimum! Everyone in the retail/advertising/print industry is in love with the soft image of silicone edge graphics, and you see them everywhere. Why? New dye sublimation fabric printing technology produces eye-catchingly beautiful and modern graphics that are easy to install and change out – anywhere. Fabric Frames are also extremely durable, made in any size or shape, lightweight, and great for large format. If you want your fabric backlit, we can do that too.

Part: SEG Fabric Frame
thick wall .070 actual
size below

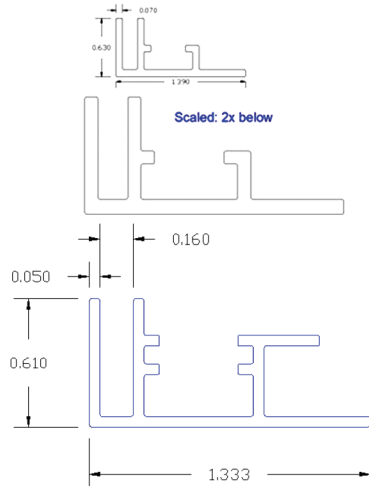

ABOVE: Silicone edge fabric frame profile.
Super low profile .610" Can be with or without
internal edge lit LEDs. Any size, any qty, 1 min.



- **Fast Signage Changes** – beautiful vanishing silicone edge into the groove on all 4 sides for a frameless graphic presentation.
- **Available in Silver or Black Anodized.**
- **Easy Installation** - hidden mounting holes, wall mount fasteners included or optional hanging systems.
- **Made to order** any size, no minimums, we stock all the extrusions, made FAST!
- **Backlit Fabric frames** feature smooth, bright light (6,000K), Cloudlight™ frames emit high intensity light for every pixel of graphic, allowing a perfectly even “cloud-like” light. The thin frames deliver a long life (50,000 hrs) and energy savings (up to 80%). Includes dimmer/flashing switch.
- **High Quality Anodized Aluminum** - 30% recycled material
- **Made in Chicago, IL USA** for FAST Delivery nationwide



Alternative way to display Fabric graphics in a FlipUp™ frame



Perfectly stretches and holds fabric graphics. Our special high tack, removable, releasable, tape is pre-installed along all 4 sides of the backer in the frame. You simply tack down the fabric. Very forgiving on size, won't show any wrinkles or stretch marks, much easier to install vs. keder or silicone edge graphics. And simple to changeout for the next graphic. Beautiful, soft, fabric image display!

Frame 1 FF-ST Flip-Up™ 1.25"



All 4 edges flip up for easy front load access. The FF-ST 1.25" Flip-Up™ wide profile front load has a satin-smooth finish, making this one of our most popular frames with Silver being the most popular finish, and many other colors below. It has an overlap on the graphic insert of ½" (.50"). This frame is ideal for vehicle use having a strong snap down onto your graphic when used with the security option (See page 17) to prevent blowouts. Also great for slat-wall, grid-wall, retail stores, restaurants, movie posters, general signage holders, directories, light boxes, double sided and thick graphics.

Insert Thickness for FFST 1.25"

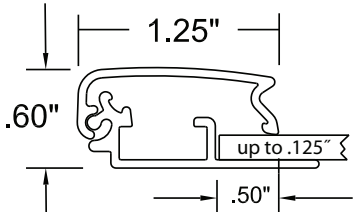

"Shallow Bottom" piece for thinner graphics up to .125" Insert Thickness

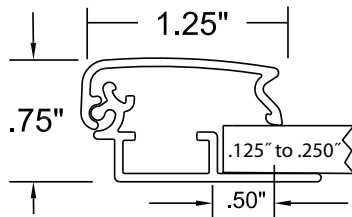

"Deep Bottom" piece for thicker graphics .126"-.250" Insert Thickness

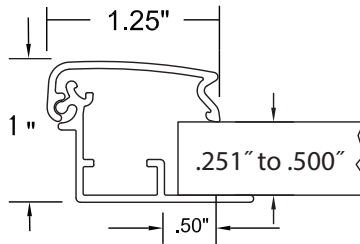

"Half Inch Bottom" piece for thicker graphics .251"-.500" Insert Thickness

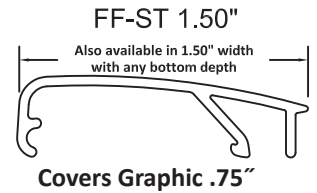

MODEL: FFST 1.25" Profile Color Choices
1.25" wide profile, for graphics up to .50" thick. Any size made, "no max limit"



MODEL: FFST 1.25" Profile Color Choices
1.25" wide profile, for graphics up to .50" thick. Any size made, "no max size limit"



Frame 1 FF-ST Flip-Up™ 2.50"



The FF-ST 2.50" Flip-Up™ wide profile front load offers a modern wider look from the FF-ST 1.25" frame. It has a flat smooth finish creating a contemporary form. The frame has an overlap onto the graphic of ½" (.50"). Has a beautiful wider appearance especially for larger graphics. Security option 1 screw down is available (See page 17).

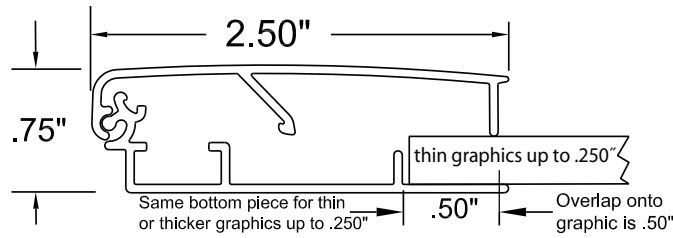

Flip-Up 2.50" Wide

MODEL: FFST 2.50" Profile Color Choices
 2.50" wide profile, for graphics up to 1/4" thick. Any size made, "no max limit"





Frame 2 FF-RP Security Flip-Up™ 1.25”

The FF-RP Flip-Up™ 1.25” wide profile front load model has a built-in rounded edge profile for instant security. In order for the frame to open, a simple flat edge spatula tool is required to prop up the frame edge, allowing your fingers to get under the frame edge to flip open. The frame has an overlap on the graphic of ½” (.50”). Security option 1 screw down is available (See page 17).

Insert Thickness for FFRP 1.25”

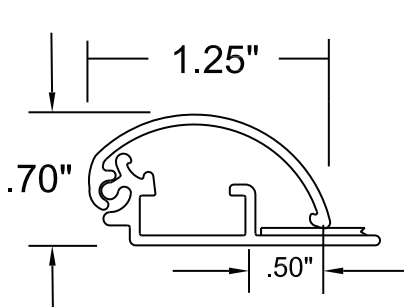

“Shallow Bottom” piece for thinner graphics up to .125” Insert Thickness

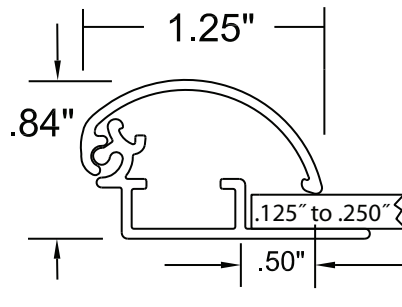

“Deep Bottom” piece for thicker graphics .126”-.250” Insert Thickness

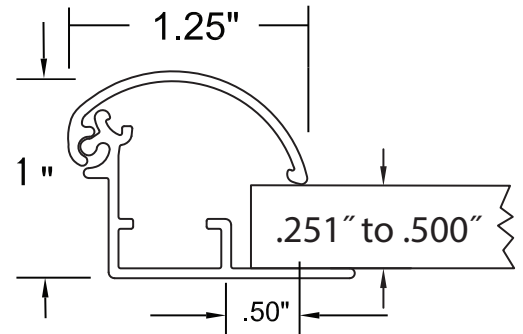

“Half Inch Bottom” piece for thicker graphics .251”-.500” Insert Thickness

1. Insert chisel-style tool under frame edge and pry up gently.

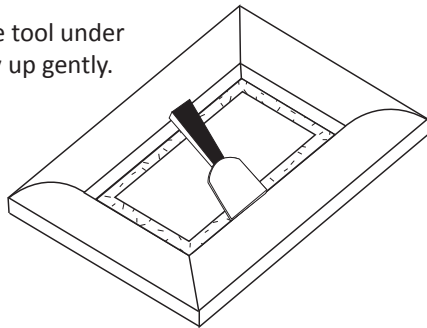

2. Use your fingers to lift up frame edge all the way.

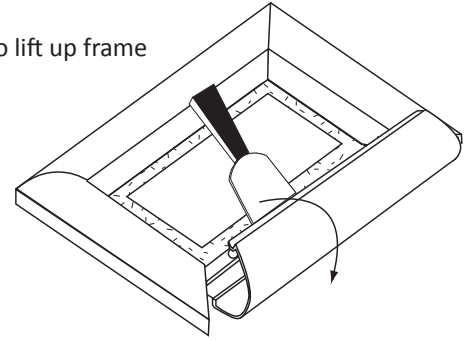

MODEL: FFRP 1.25” Profile Color Choices

1.25” wide profile, for graphics up to .50” thick. Any size made, “no max limit”



Frame 2 FF-RP Security Flip-Up™ 1.75"

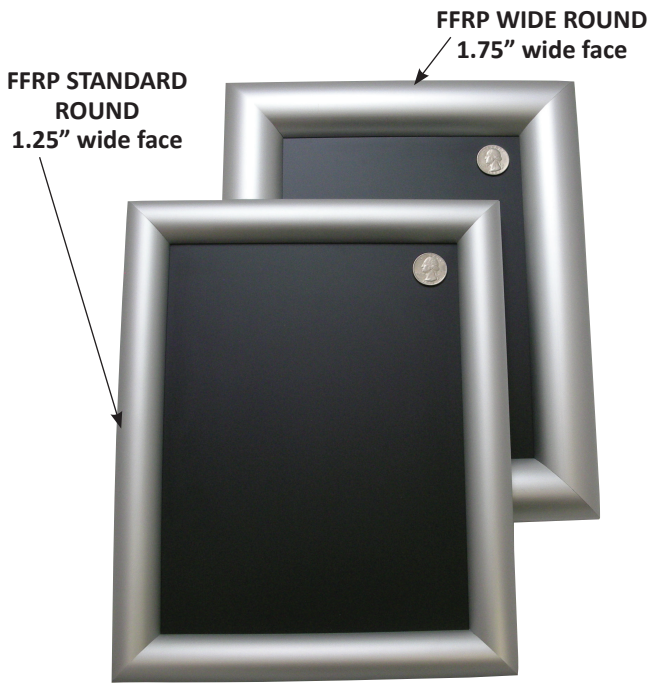

The FF-RP Flip-Up™ 1.75" wide profile front load model has a built-in round edge profile for instant security. In order for the frame to open, a special flat edge tool is required to prop up the frame edge allowing your fingers to get underneath the frame edge to flip open. The frame has an overlap on the graphic of 1". Security option 1 screw down is available (See page 17). Best choice for vehicle graphics.

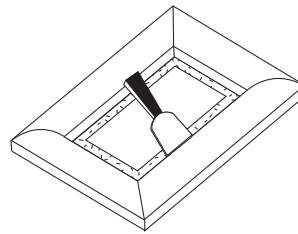

1. Insert chisel-style tool under frame edge and pry up gently.

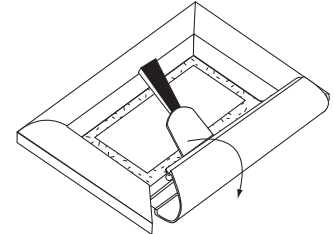

2. Use your fingers to lift up frame edge all the way.

Insert Thickness for FFWRP 1.75"

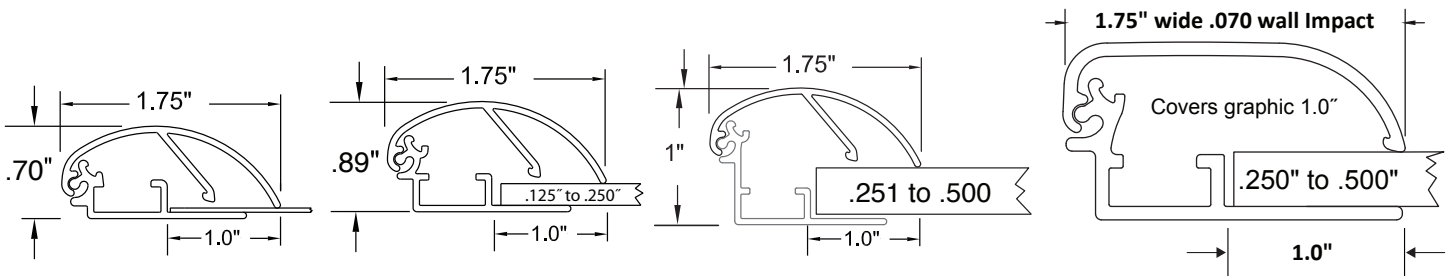

"Shallow Bottom" piece for thinner graphics up to .125" Insert Thickness

"Deep Bottom" piece for thicker graphics .126"-.250" Insert Thickness

"Half Inch Bottom" piece for thicker graphics .251"-.500" Insert Thickness

"Half Inch Bottom" piece for thicker graphics .251"-.500" Insert Thickness

MODEL: FFWRP 1.75" Profile Color Choices
 1.75" wide profile, for graphics up to .50" thick. Any size made, "no max limit"



Frame 3 SL-ST edge load Slide-In™ 1.0"

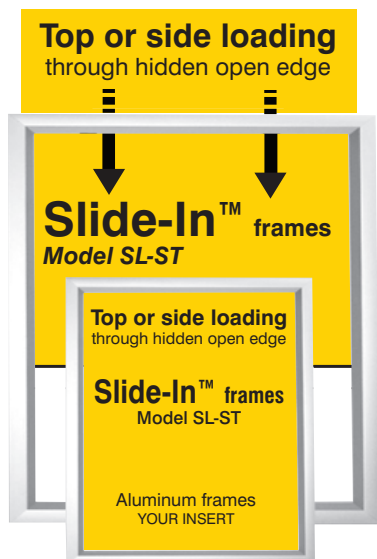

The SL-ST Slide-In™ 1.0" wide profile top or side loading frame is the simplest and most economical frame we offer. Unlike the Flip-Up™ frame, the Slide-In™ frame edges do not flip open, but have a hidden open cavity behind the frame where the graphic slides in. This frame can be ordered and mounted landscape or portrait with the opening being on the long side or the short side of the frame. The frame can be mounted side-by-side making an illusion of one long frame with multiple graphics, great for menu boards. The Slide-In™ frame holds graphics up to .250" thick and only 3/8" (.375") of the graphic perimeter is covered by the frame edges. The frame is one solid aluminum piece with no moving elements. Anti-tamper security options 3a and 3c are available such as a removable top that screws in to completely seal the loading edge (See page 17).

Insert Thickness for SLST 1.0"

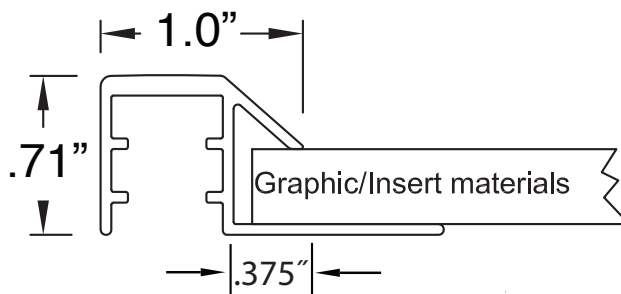

Slide-In frame can accept maximum of .125"~.250" as max thickness.

MODEL: SLST 1.0" Profile Color Choices

1.0" wide profile, for graphics up to .50" thick. Any size made, "no max limit"



Frame 4 Mini Flip™-Up .60"

Model: MiniFlip™

.60 inch wide profile
.60 thick, square
corners only

SILVER anodized and
Black powder only

Only accepts thin
poster graphic

Thin graphics only

Any size made

The Mini Flip™-Up .60" wide profile front load frame is also known as the "skinny or slim edge" frame. This frame is the slimmest frame we make. Custom cut to any size up to a maximum of 36" x 48".

All 4 edges flip open for front loading.

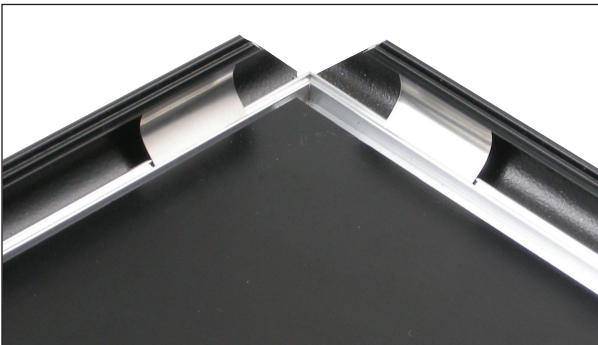
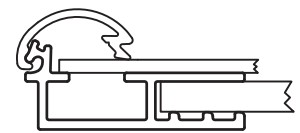
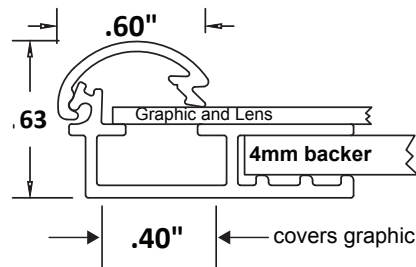

MODEL: Mini Flip .60" Profile Color Choices



New SQUARE Mini Flip Frame



Square Mini Flip profile is only .60" wide, all 4 sides flip up. Slim stylish great looks !



Attractive, slender SQUARE Mini FlipUp frame. Easy front load graphic loading, all 4 sides flip up. Any size made, 1 or 10,000. Silver or Black stock colors.

Mini Flip-flat square top

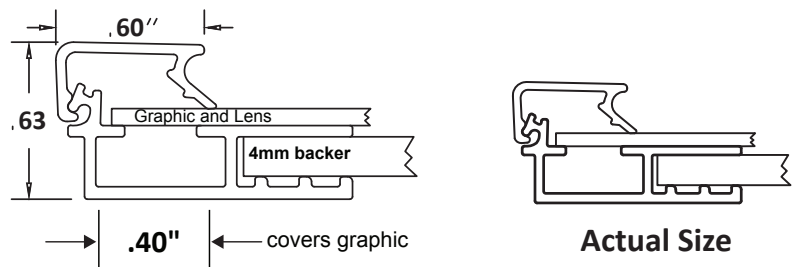

Frame 5 RCOR1.0™ Flip-Up™ Round Corner 1.0"

**Model: RCOR1.0™
ROUND CORNERS**

1 inch wide profile,
.43" thick, round
corners only

SILVER anodized and
Black powder only

Thin graphics only

Any size made

The RCOR1.0™ Flip-Up™ Round Corner 1.0" wide profile front load frame has rounded corners vs. the traditional square corner frames. The frame beautifully displays thin poster graphics, custom cut to any size.

All 4 edges flip open for front loading.

RCOR1.0 Flip-Up™ Miter or Round Corner 1.0"

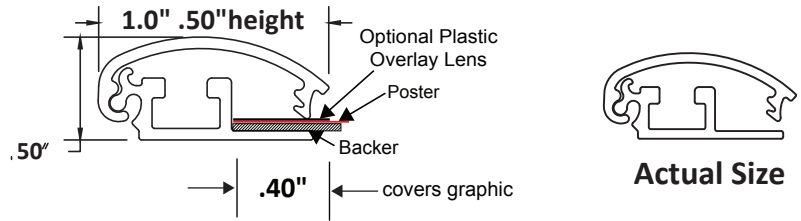

Can also be made as regular mitered frames



MODEL: RCOR 1.0" Profile Color Choices



Frame 6 RCOR1.25™ Flip-Up™ Round Corner 1.25”

**Model: RCOR1.25™
ROUND CORNERS**

1.25 inch wide profile,
.75” thick, round
corners only

SILVER anodized and
Black powder only

Thin graphics only

Any size made

The RCOR1.25™ Flip-Up™ Round Corner 1.25” wide profile front load frame has rounded corners vs. the traditional square corner frames. Custom cut to any size. Security option screw down 1 is available (See page 17).

All 4 edges flip open for front loading.

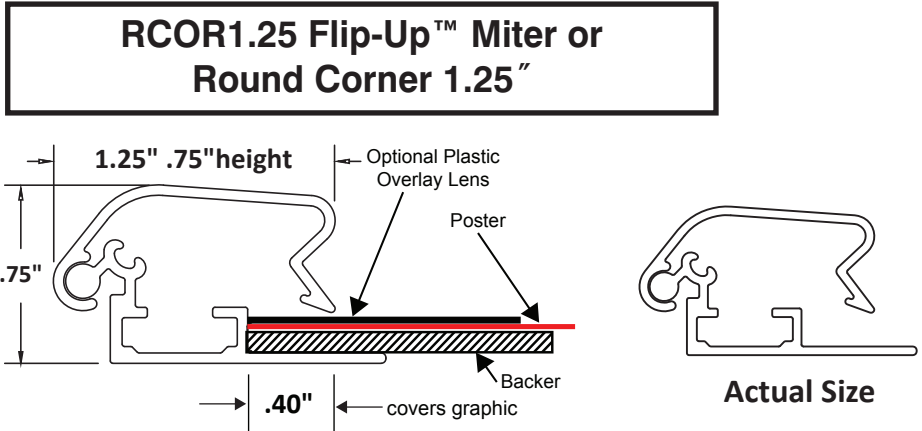

Can also be made as regular mitered frames



MODEL: RCOR 1.25” Profile Color Choices

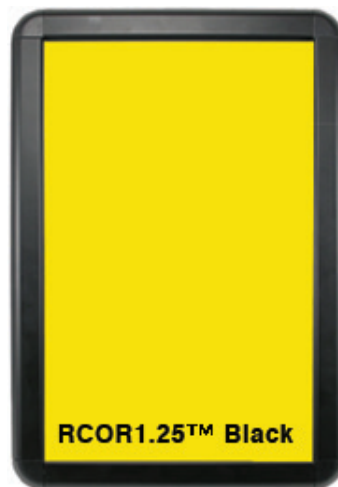

Frame 7 Armored Steel Sign Holder



Frame 7 armored steel sign holder is our highest security sign holder. This frame is tough enough to survive any environment and stay looking beautiful. The Armored Steel Sign Holder comes in two sizes only: 8.5"x 11 and 11" x 17 sheet holding sizes. Wall or Pole Mount. Tough enough for prisons or high vandalism environments.

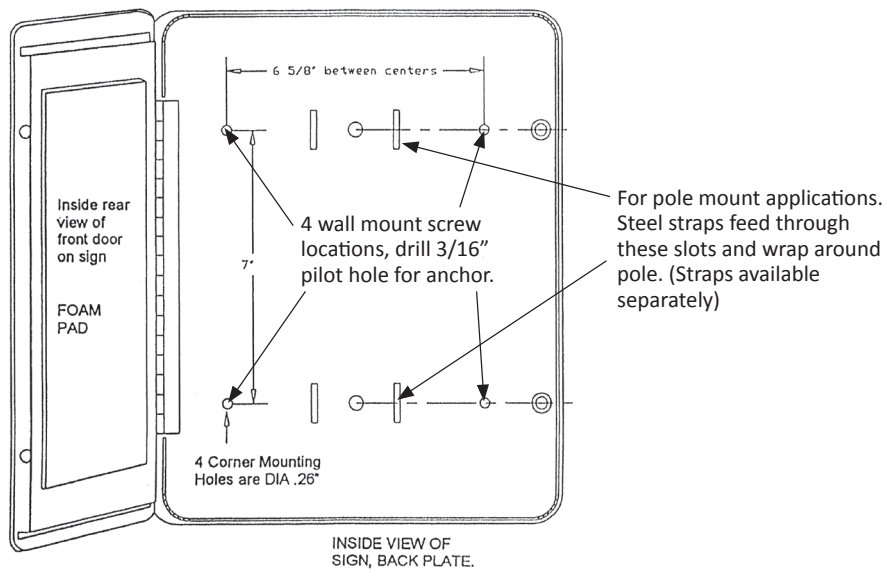

MODEL: Armored Steel Sign Holder Color Choices: BLACK ONLY

**Super Secure
Wall or
Pole Mount**

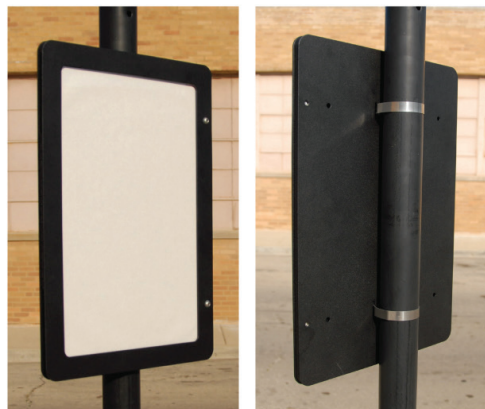

We can make frames with unique angles with our FlipUp™ frames



Custom Imprinted Frames



Banner Grip™ 4.0” wide profile front load frame (using our patented clamps or hook system)



136” x 96” hi-res banner

All 4 edges flip open for front loading.

Our Banner Grip™ frame will stretch ANY size, banner material to a drum-tight finish for a perfect appearance. Only raw edge banners are required, but can stretch any banner with grommets, pole sockets or hemmed edges. The banners are stretched using our patented aluminum alloy clamps with interlocking teeth that grip onto the banner but do not tear or pierce it. The clamps are easily tightened to stretch out the banner perfectly, leaving no sags or wrinkles anywhere -guaranteed. No other frame can do this, patent protected. The frame can be used in or outside, made of high-grade aluminum alloy and stainless steel and will not rust or drip corrosive marks. The Banner Grip™ can also hold rigid, but flexible substrates like solid plastic sheets or sheet metal signs up to 1/16” thick -eliminating any “waviness” and making such signs perfectly “flat.” the frame ships in 60”to

80” sections (for larger frames) by UPS ground – for fast assembly on-site. Longer sections are seamlessly joined with our exclusive “joiner strap” for easy shipment and on-site assembly. Security option 1 screw down is available (See page 17).

**MODEL: Banner Grip™ 4.0”
Profile Color Choices**

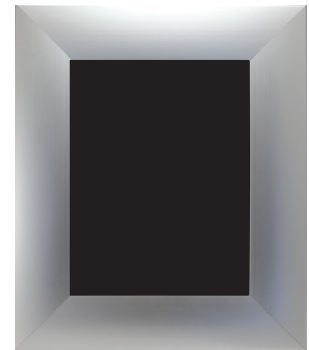

Silver anodized

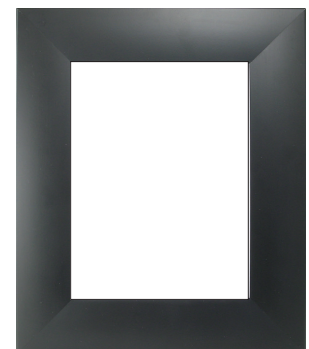

Black powder

Parts of Banner stretching frame

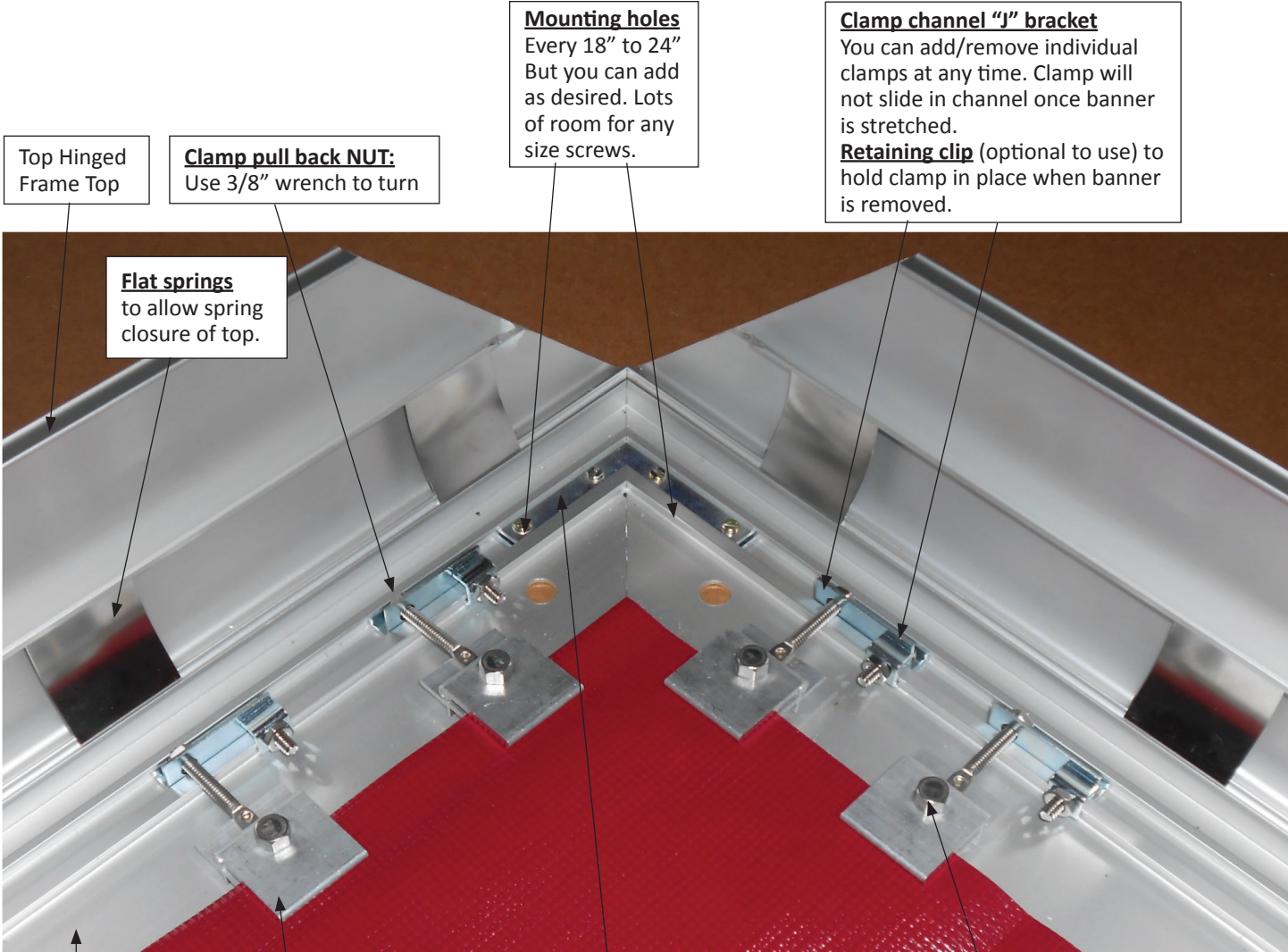

Bottom of frame

Clamp assembly

Corner angle that slides into and tightens into the 2 corner channels (1 of 2).

Clamp closure screw.
Hex Head Style, finger tighten first, then use 3/8" wrench to tighten.

Spring loaded jaws stay open to easily engage onto banner edge

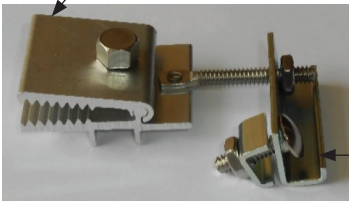
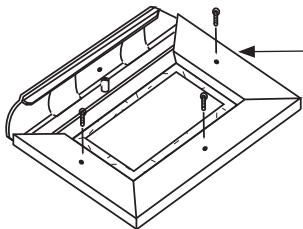
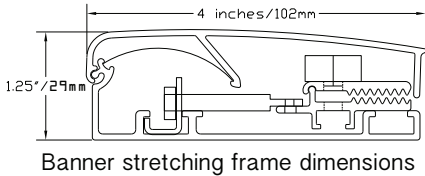

Photo: Clamp and J bracket assembly. This is the clamp assembly that fits into the channel and clamps onto banner to pull it tight.
"J" Bracket



Optional:
Option 1 Screw Down
Screw down option so all 4 edges of frames are tightened down onto banner to prevent unauthorized opening of frame sides. Uses security screws, or can use regular screws.

Banner stretching frame, continued.....

As an alternative to our Clamps pictured on page 20, you can also use our Hook method to engage grommet holes to tighten your banner. See below.

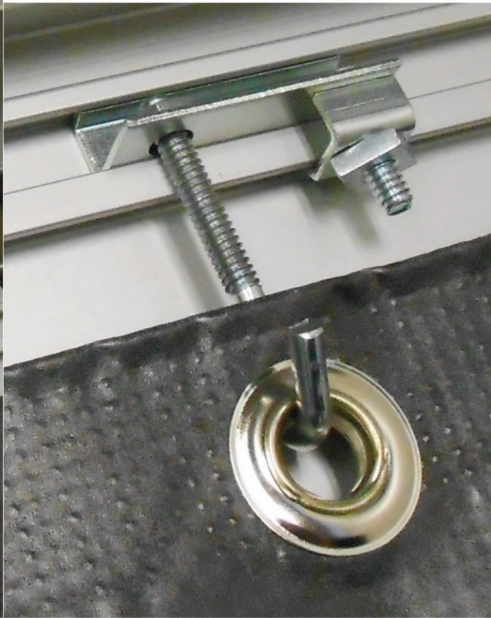
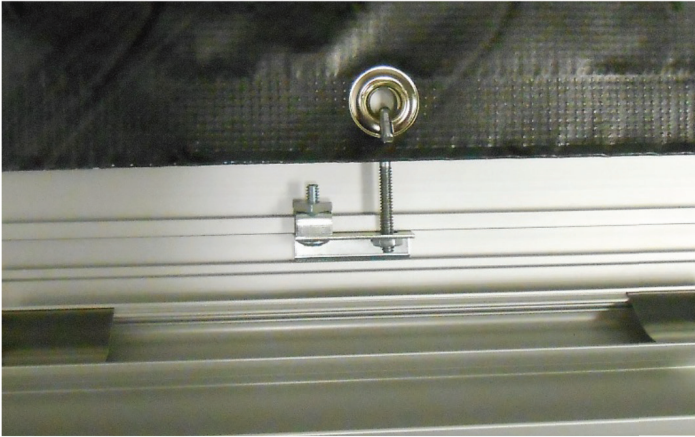

Joiner straps connect longer sections of Banner frames 48" to 80" long, for opening ease and so that we can ship large frames by UPS. Seams are practically invisible! Easy assembly on site.

OR, we can ship full 145" sections by Semi on a pallet.

Banner Grip™ in use at actual sites:



Size of Banner Grip™ frame above: 7.5 feet x 34 feet, Inches= 90" x 408", cm= 229cm x 1036cm
Banner is perfectly stretched -no sags or wrinkles. Beautifully framed. Easy to change to another banner.



Canada install: Nice, clean framed look. No ugly straps, hooks, hardware or edges visible -all hidden ! Size of Banner Grip™ frame above: 10 feet x 16 feet, Inches= 120" x 192", cm= 305cm x 488cm

Photo above: Tampa Bay History Center Bldg. (6) Banner Grip frames installed on custom made mounts, size 8.5 feet wide x 27 feet height, each banner.



California Pizza Kitchen



NYC 9/11 Memorial Banner



Banner in Green Bay Packer fans territory

Framing of the Mona Lisa

The original Mona Lisa is 30" tall x 20.875" tall. We obtained a high resolution photograph of the original. Maintaining the correct proportions, we enlarged the image to 136" tall x 96" wide. It was digitally printed on vinyl banner material, 4 color process, UV inks. Here we show how beautifully our frame can display this image, on the side of one of our factory buildings. See below.



Mounting frame sides to our building.



Hanging banner with our patented mini clamps.



Adding clamps all around.



Clamp tightening finished, frame sides closed, 90 minutes total installation time.

Mona Lisa
136" tall x 96" wide.

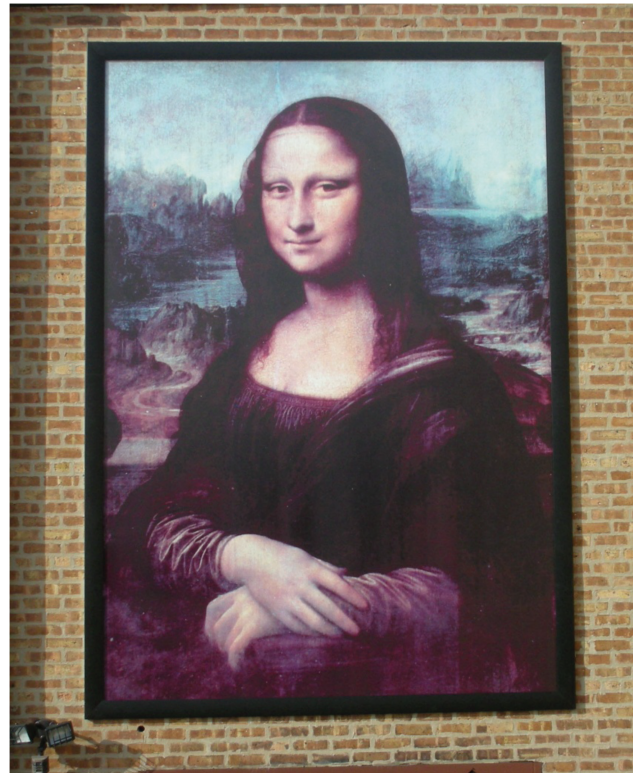

Beautifully displayed, not a crease or wave anywhere, picture perfect.

Outdoor or indoor use, aluminum and stainless steel components, long lasting, no rust drips on wall ! Patents Pending and Patented.

COPYRIGHT 2023 MADE in the USA !

Introducing Banner GripFlip™



Amazing new flip up frame that stretches any size vinyl banner within the frame, and the tops snap down to cover the banner edges. There are no visible external screws, and the profile is only 2.5 inches wide!

Create large and beautifully, drum-tight stretched vinyl banner displays!

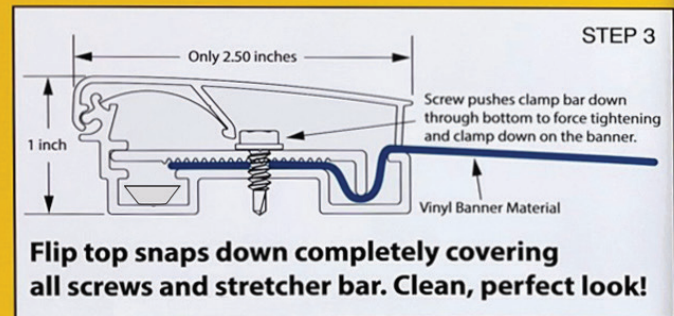
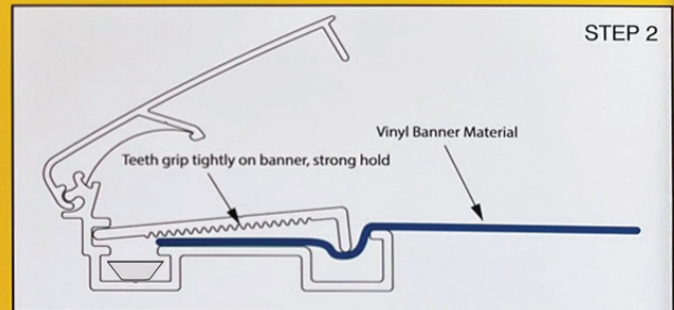
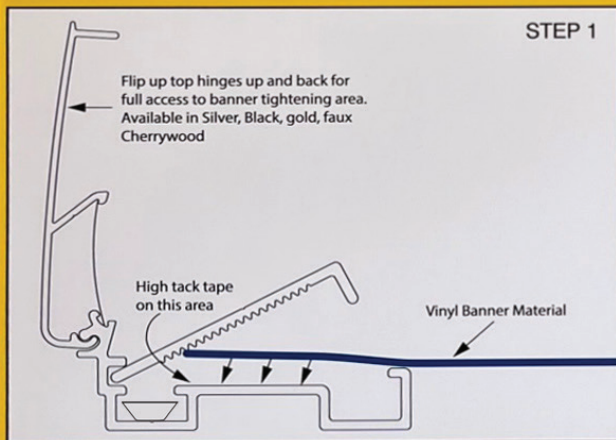

Patents Pending. All Rights Reserved.

All 4 frame sides flipped down to cover all the stretcher bars and screws. Drum tight and beautifully displayed! No visible screws. Indoor or outdoor use.

Banner Grip™ Jr for Building sides and Trucks



Only our frame offers perfect linear alignment with our included "Joiner Straps." Longer sections join easily and perfectly for the best results!

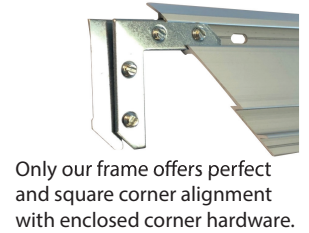
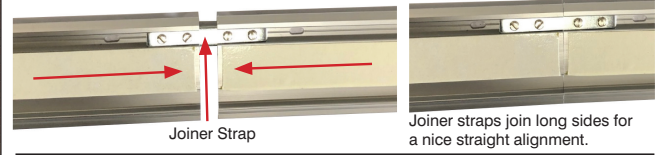

Only our frame offers perfect and square corner alignment with enclosed corner hardware.

How screwing down the CAP tightens the banner:

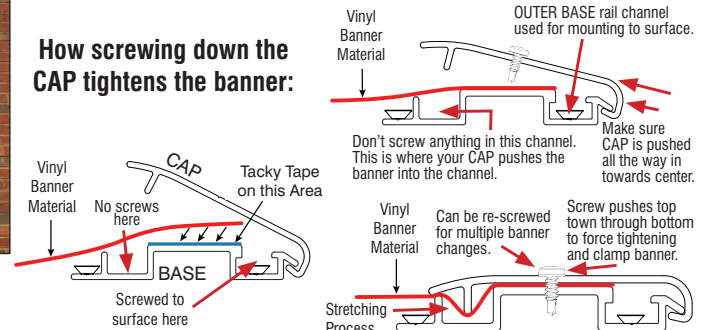

The tacky tape is used for positioning only. Once CAP is screwed down, the CAP and screw tightly compress down to hold vinyl banner in place within the frame.

Beautiful Banner Display, Wrinkle free, Drum Tight, Won't blow out in any winds, perfect for Semi Trailer use

For Trucks, more attractive than wraps because rivets, gouges, dents are completely covered up for a smooth professional appearance.

Features:

- Our frame stretches and tightly holds vinyl banner material.
- Much less expensive and easier to install than adhesive vinyl "wraps."
- Can change out your own ads, don't need to pay for expert sticky "wrap" installers.
- More attractive than wraps, because rivets, contours on truck body are completely covered up.
- Super secure and tight. • Any size. Made in Chicago.



Beautiful Framed Ad on Your Truck



Step 1. Install BASE plate on side of truck or semi trailer



Step 2. Hang vinyl on frame



Step 3. Attach TOP frame CAP to tighten and secure banner



Billboard banner is super tight and secure in frame on the side of your truck!

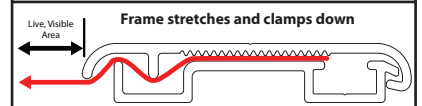

Banner GripFlip™ Banner Stretching Frame

Patents Pending. All Rights Reserved.

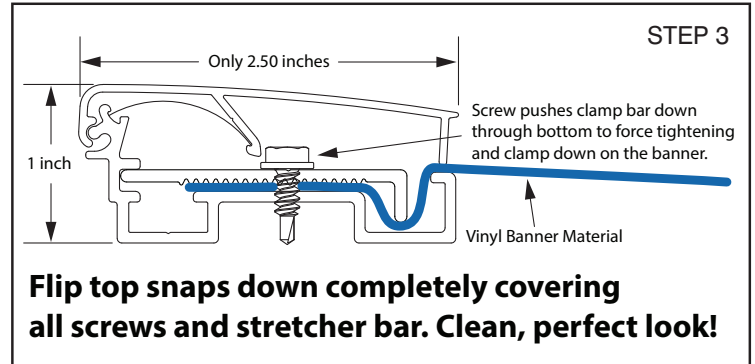
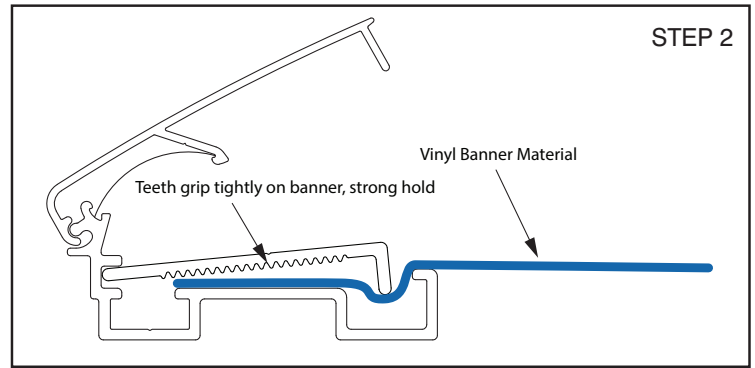
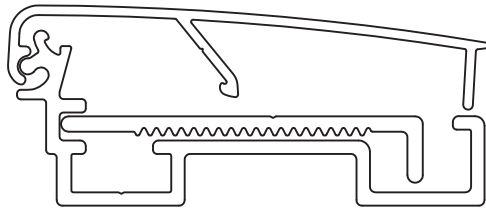
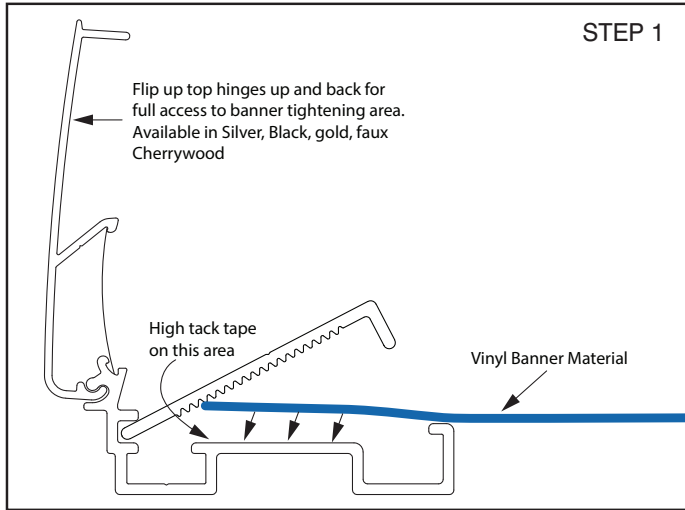

Banner Grip JR™ screw down stretching frame

How screwing down the CAP tightens the banner:

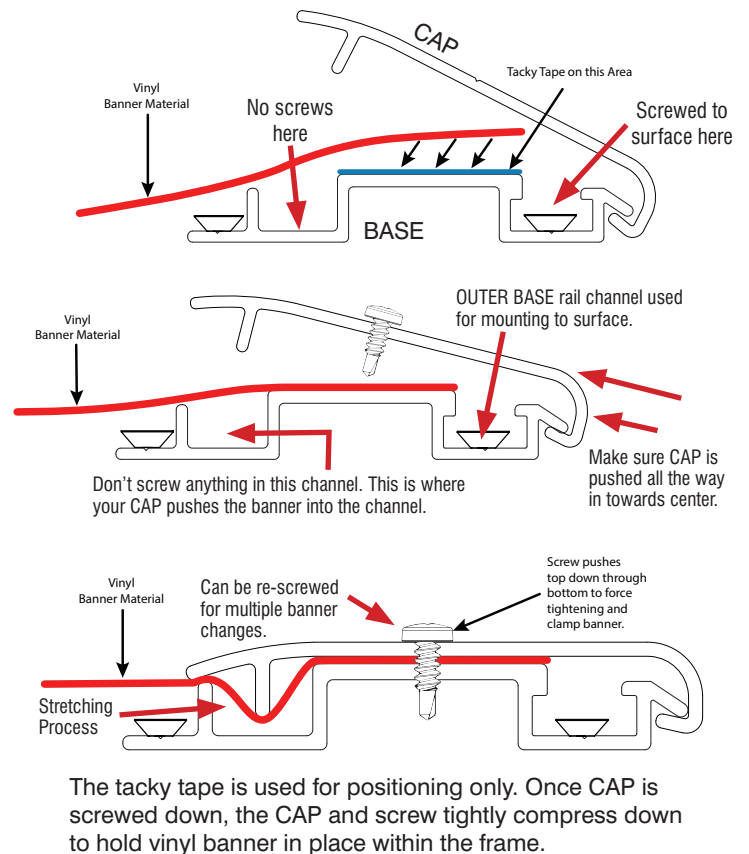
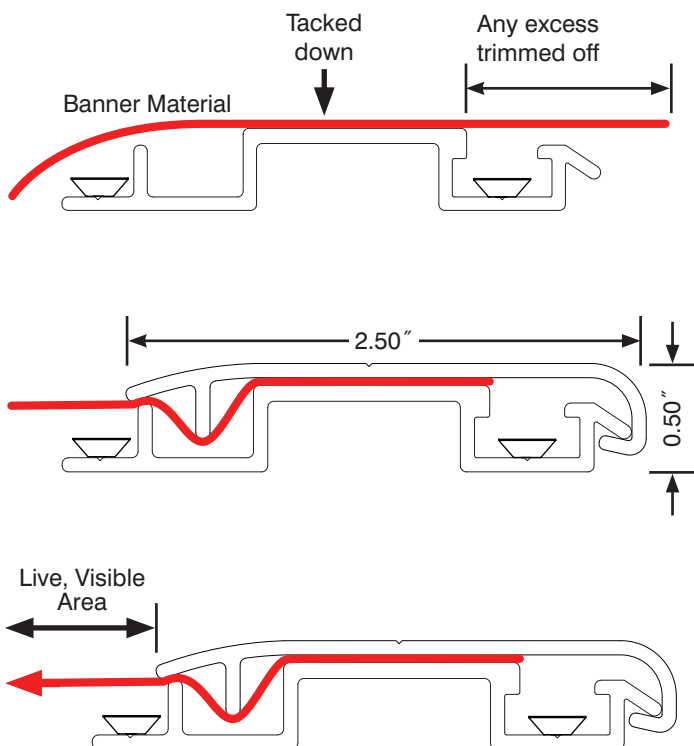

Banner Stretching GripFlip™ frame below



Banner Stretching "JR" model below



Pole stands and A Frames made ANY size or height with ANY of our frames



Pole stands or “A” frames made regular, tall, skinny, wide, short, anything you want 1 or 10,000 ! Pictured here with our RCOR1.25 round corner frames. But, we can make with any of our square mitered frames in any of our color choices as seen in pages 4-12. Order minimum: 1



“A” Frames ANY size

You can choose the size, profile choice, color and height of the frames.

Pictured here: Silver and black frames –BUT, any color or profile as seen in pages 4-12 can be used.

Silver and black are the only square pole colors available for the pole or A frame underbodies.

Order minimum: 1

Security Options (may incur additional cost)

Option 1: "Screw Down Option"

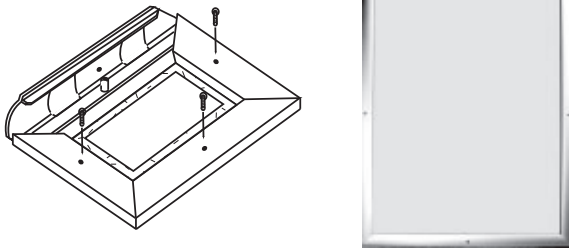

Option 1 "Screw Down Option" – this option is available for Frame 1, 2, 6, and 7. The screw down option locks down all 4 flip down sides to prevent theft or wind blow out. Accommodates inserts up to .500" (1/2") thick.

Option 3a: Blocker™ Screw (Slide-In™ only)

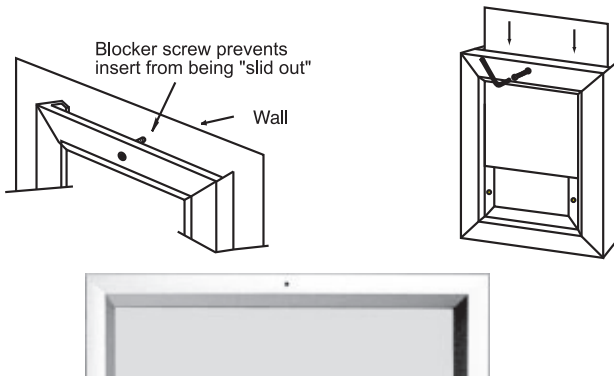

Option 3a "Blocker™ Screw" – Only available for Frame 3 Slide-In frame. The blocker screw is the quickest security option we offer -with no frame parts to remove. The security screw is simply a center mounted screw hardly visible on the slide-in portion of the frame. Blocks inserts from being "slid out."

Option 3c (Slide-In™ frame only) Removable frame edge

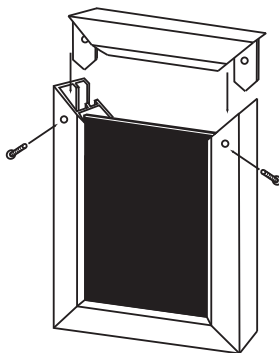

Option 3c "Removable Frame Edge" – Only available for Frame 3 Slide-In frame. Option 3c is our most popular security option for the Slide-In™ Frame. This option completely closes all four sides to prevent removal of your graphic. Two front mounted security screws are placed on the upper section below loading side of the insert. To insert graphic, the frame edge is removed, graphic loaded, frame edge replaced.

Security Screws and Tools for option 1, option 3a, and option 3c security add-ons. The security options require tools as shown here. We use "Pin in TORX" tamper resistant screws that can open with only a special security tool not available to the general public. Pin in HEX style screws are also available upon request.

Insert Bit and L Key to remove TORX security screws. We can supply hand operated "L" keys or bits to use with manual or cordless power drivers.

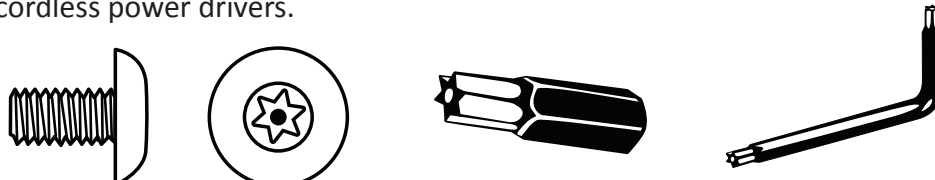

Overlay lenses, frame backers and other options



Overlay

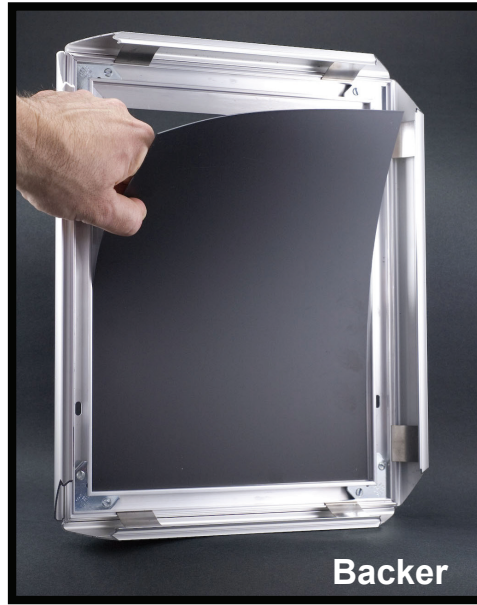

Backer

Overlay lenses: Protect and enhance the beauty of graphics with a clear plastic protective overlay windows approximately .020" (20mil) thick. Overlays are high grade PETG plastic, are super clear, will not crack and are ideal for use in our frames. Totally clear and non-glare options available, as well as .040 - .060" thicker lenses.

Backers: For the Flip Up™ frames the backer is .040" (40mil) thick black styrene plastic for thin inserts. For slide-In™ frames the backers are typically .157" (4mm) thick black corrugated plastic. Other backer options are available including hardboard and aluminum. We use .040" thin backers to make the frames as slim as possible, since once frames are mounted on the wall, the frames are super rigid and sturdy.

Hanging Options: All of our fast change frames are available with basic drywall or hardwall mounting hardware. Other mounting options: D-Rings great for hanging from ceiling fixtures or in windows. Magnet backs for steel doors or walls, Slatwall or Gridwall hooks, Double Sided Tape or Velcro.

Double-Sided Frames: Our frames can be mounted back to back to create a double sided frame. Two graphics are necessary.

Floor Stands: we can make any size frame A Frames and floorstands, 1 or 10,000 no minimum and fast!

Alpina Acrylic Stand Off Frames

Acrylic Stand Off Frames provide a modern, professional, durable method for displaying graphics. Your graphic is easily sandwiched between the Acrylic panels, on positioning lines etched into the acrylic, so centering your graphic is simple. We are the only acrylic frame that offers this lasered positioning feature.

We provide the aluminum mounting hardware that securely grips the acrylic sections together (in Brushed Stainless or Jet Black). Your graphic or artwork is stylishly highlighted and blends perfectly into corporate, retail, restaurant, and any other locations. Made in Chicago on our new laser machine so we are able to complete your etching projects, no matter how straightforward or intricate.

Here are some recent applications:

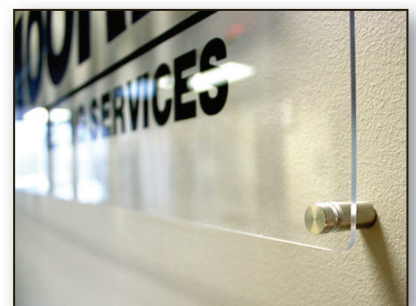
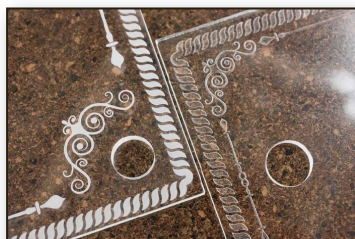
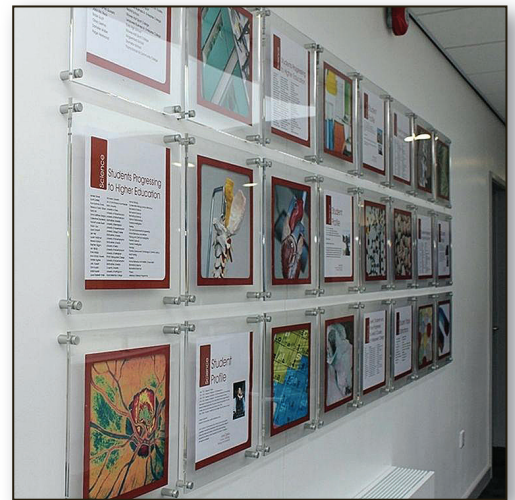

Bollard Mount, Single and Dual Frame System

Bollard frames, made in the USA, any size -for any type bollards



Bollard Mount, Dual Frame System



Our frame offers "double" the advertising exposure and an attractive appearance. Made in any size or color you want. Pictured above are frames to hold super common 24" x 36" posters.

Cubicle Sneeze Dividers

- Made to any length or height
- 1/4" super clear, almost invisible Acrylic
- Sits on top of cubicle, no drilling or damage to Cubicle, fast, easy removal
- Easy, do it yourself install, no tools required
- Protects employees in adjacent cubicles when standing up



Other Sneeze Guard Products

Made to any length or width you want. We can add a half moon slot at bottom, or no slot, or any size or shape slot you need. Precision cut on our high end laser machine. Ships flat, legs snap on in seconds for immediate deployment.



Acrylic stand up Sneeze Shields with Acrylic Legs

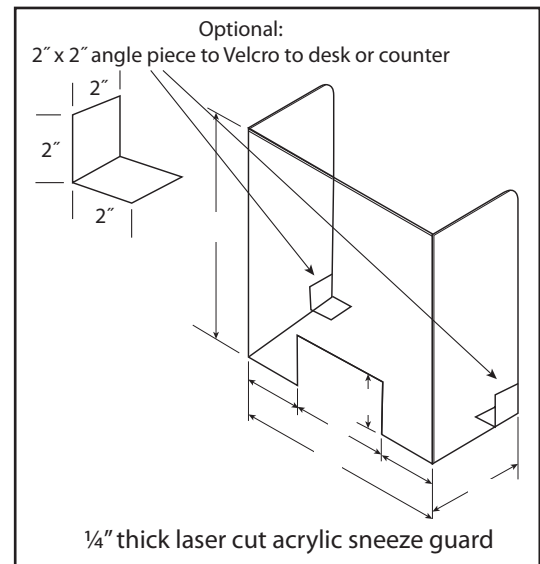

Customer Supplied Pictures of frame installations:



Cloudlight LED frame



Cloudlight LED frame



Customer Supplied Pictures of frame installations:



NYC

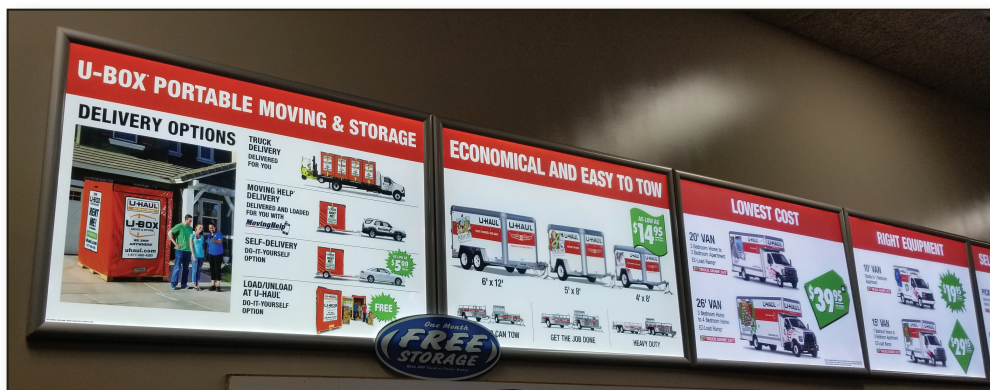

Cloudlight LED frame

Client supplied photos of our frames

